

| | | |
|--------------------------------|------------------------------|--------------------------------|
| Make: Mazda | Model: Bt-50 | Body Style: Utility |
| Year: 2008 | Registration: EHE724 | Reg Expiry: 22 Feb 2025 |
| WoF Expiry: 21 Oct 2024 | Odometer: 238,570 Kms | Good No: 26203613 |
| VIN: MM0UNY0E30066667 | Next Service: overdue | Service History: Yes |

Note: This report is not a warranty

This report is a guide only. Consideration is made for age and mileage. Parts have not been dismantled or diagnostic testing undertaken. The vehicle has been driven up to 50km/h from cold. The Vendor recommends a full mechanical inspection prior to purchase and this can be arranged for an additional charge.

Key:
S = scratch
D = dent
R = rust
PT = paint defect
C = crack
P = pin dent
* = decals
SC = stone chips
W = significant scuffs

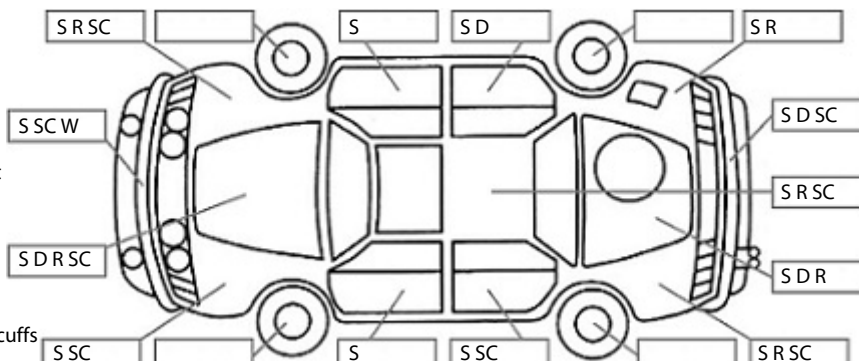

Body Inspection Comments
Headlights are faded. Front bumper poor fit

Note: some defects & blemishes may not be displayed in the diagram

Conditions During Body Inspection: Dry

Under Carriage & Under Bonnet Inspection Comments
Requires front brakes. Tested battery and failed. Runs on diesel fuel

Interior Comments

| | |
|-----------|------------------------|
| Seats | marks |
| Carpets | Average |
| Panels | scuffs scratches marks |
| Dashboard | Average |

General Comments
Turbo hissing (possibly hole in piping or loose clamps, didn't see anything obvious at inspection time). Noisy when pressing clutch cable and changing gears (possibly release bearing). Mirror adjust nw

Road Conditions During Test Drive: Dry

Engine Timing Mechanism: Cambelt
Evidence of Cam Belt Replacement: Yes Kms: 229,000

| | Pass | Fail | N/A |
|---|------|------|-----|
| Engine | | | |
| Oil level | ✓ | | |
| Smoke & fumes | ✓ | | |
| Performance | | ✓ | |
| Noise | ✓ | | |
| Cooling System | | | |
| Coolant condition | ✓ | | |
| Performance | ✓ | | |
| Radiator / Hoses (visual) | ✓ | | |
| Transmission | | | |
| Operation | ✓ | | |
| Noise | | ✓ | |
| Clutch | | ✓ | |
| CV joints | | | ✓ |
| Wheel bearings | ✓ | | |
| Brakes | | | |
| Performance | | ✓ | |
| Hand Brake | ✓ | | |
| Tyres (lowest observed tread depth of tyres) | | | |
| Left front | 3.0 | mm | |
| Right front | 4.0 | mm | |
| Left rear | 5.0 | mm | |
| Right rear | 5.0 | mm | |
| Spare | Yes | | |
| Suspension | | | |
| Suspension performance | ✓ | | |
| Steering performance | ✓ | | |
| Shock absorbers | ✓ | | |
| Air Conditioning / Heater | | | |
| Operation | ✓ | | |
| Electrical / Accessories | | | |
| Head lights | ✓ | | |
| Tail lights | ✓ | | |
| Indicators | ✓ | | |
| Dashboard warning lights | ✓ | | |
| Wipers (front & rear) | ✓ | | |
| Window winder FL | ✓ | | |
| Window winder FR | ✓ | | |
| Window winder RL | ✓ | | |
| Window winder RR | ✓ | | |
| Rear view mirrors | | ✓ | |
| Radio (basic test only) | ✓ | | |
| CD (basic test only) | ✓ | | |
| Number of keys | 1 | | |
| Central locking | ✓ | | |
| Remote locking | ✓ | | |
| Sat. Nav. (basic test only) | | | ✓ |
| Reversing camera | | | ✓ |

Inspected by: Gary Adams Date: 25 Jul 2024

I have read and understood this condition guide. Name: Signature: